

### Ska Base

**RTL47312** - 33 W - 3200 lumen - 60° - Wide / 33 W / 4000 K / CRI > 92

#### DESCRIPTION

The SKA projectors are particularly suitable for the lighting of commercial environments such as shops and malls. The high lighting performance allows adequate illumination of the exhibition surfaces and exposed objects. The SKA projectors are equipped with selected drivers and CoB LEDs (prime brand) and the light color qualities (CRI > 90 and SDCM < 3) guarantee an excellent color rendering of the illuminated objects. The light emission is managed with high efficacy interchangeable optics to obtain maximum efficiency and maximum flexibility. Available On / Off and DALI versions.



Switch **On:Off**

#### PRODUCTS CHARACTERISTICS

installation type	<b>Track / Ceiling projectors</b>
material	<b>Aluminum</b>
Color	<b>Black</b>
Power	<b>33 W</b>
Lumen output - Full emission	<b>3248 lm</b>
Efficacy	<b>98 lm/W</b>
Dimensions	<b>95 x 207 mm.</b>
net weight	<b>1,1 kg.</b>

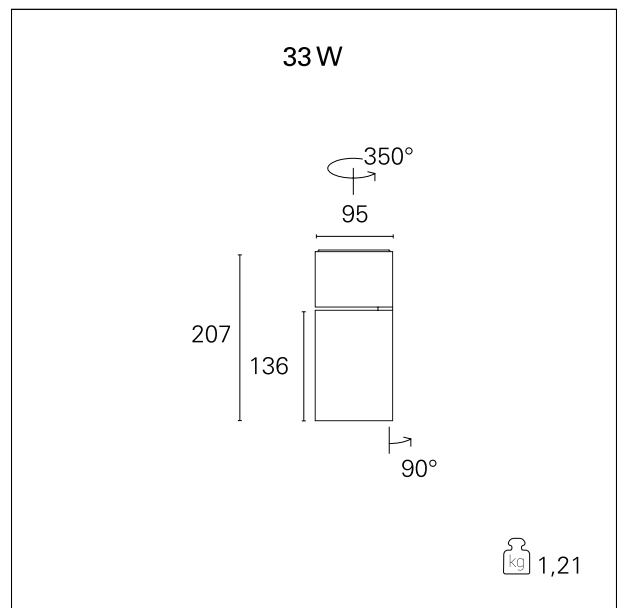

#### ELECTRICAL CHARACTERISTICS

feeding	<b>220÷240 V</b>
driver	<b>On:Off</b>
Insulation class	<b>Class I</b>

#### MECHANICAL CHARACTERISTICS

product IP rate	<b>IP20</b>
-----------------	-------------

### Ska Base

RTL47312 - 33 W - 3200 lumen - 60° - Wide / 33 W / 4000 K / CRI > 92

#### LED SOURCE DETAILS

led source type	<b>CoB Led</b>
Photobiological risk	<b>RG 1 Low risk ( IEC 62471 )</b>
LED brand	<b>Bridgelux or equivalent</b>
LED current	<b>800 mA</b>
Service lifetime	<b>L80 / B20 - 50.000 h.</b>
Light temperature	<b>4000 K</b>
CRI	<b>CRI &gt; 92</b>
SDCM	<b>&lt; 3</b>

#### DRIVER CHARACTERISTICS

driver	<b>On÷Off</b>
Operating temperature	<b>-20°C ÷ 45°C</b>

#### LIGHTING DETAILS

luminous effect	<b>wide</b>
Beam angle - direct	<b>60°</b>
Cut Hood	<b>32°</b>

#### PHOTOMETRIC

