

Saturno

GRF13201 - ø 110 cm. - 8x max 40 W -

DESCRIPTION

Saturno is a pendant luminaire characterized by a fabric shade mounted on a frame and by its ring shape. It is complete with a translucent parchment screen and is equipped with E27 sockets. It allows to obtain diffused light effects and is available in different diameters. Saturno can be installed as pendant up to 350 cm cables longer. thanks to four steel cables covered with transparent sheath, adjustable in height with self-locking "grip lock" system. Power cable in FEP+PVC transparent.

Switch

On+Off



PRODUCTS CHARACTERISTICS

installation type
material
Color
Power
Diameter
net weight

High Bays
Fabric
Linen
8x max 40 W
ø 110 cm.
4,5 kg.

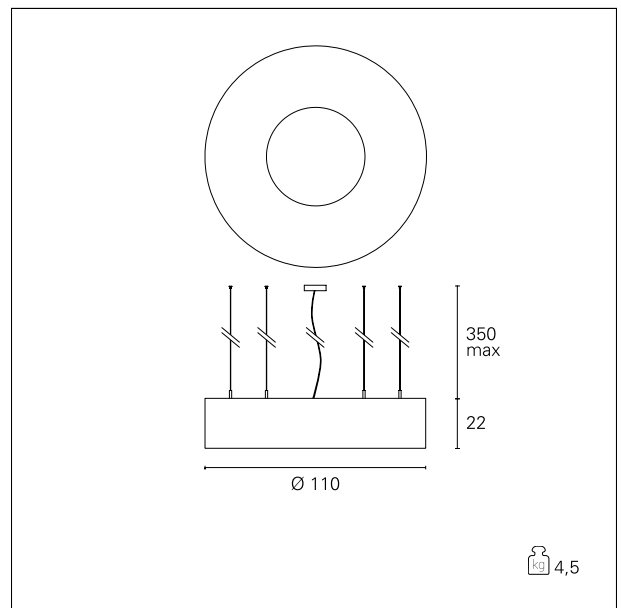

ELECTRICAL CHARACTERISTICS

feeding
driver
Insulation class

220÷240 V
On+Off
Class I

MECHANICAL CHARACTERISTICS

product IP rate

IP20

Saturno

GRF13201 - ø 110 cm. - 8x max 40 W -

LED SOURCE DETAILS

led source type	LED / IAA
Light source connection	E27

DRIVER CHARACTERISTICS

driver	On=Off
--------	---------------

LIGHTING DETAILS

emission	Downlight
----------	------------------